

E Series

Automatic Engine Overspeed Shut Down Valves

A range of easily installed diesel engine air intake valves which automatically close on engine overspeed.



wyndham|page

wyndham | page

Wyndham Page Ltd is headed by Freddy Page-Roberts who brings over 20 years' experience in the diesel safety industry and was previously managing director of Chalwyn Ltd.

Norman Love, a very well-known and respected figure in the diesel safety field, also brings his considerable technical expertise to the Company.

Norman has represented the UK to help develop the current European safety standard – EN1834:2000 for diesel engine protection in hazardous areas - and was the founder and managing director of Flametec as well as a past director of Chalwyn and Pyroban.

Application

The E Series of Wyndham Page automatic overspeed shut down valves are designed for situations where flammable gas or vapour may enter the atmosphere in an area in which a diesel engine is operating.

Should such flammable material be drawn into the engine intake this may result in uncontrolled engine overspeed and a situation in which shut down of the normal diesel fuel supply may fail to stop the engine.

Under these circumstances a rapid shut down of the engine is required by immediate closure of the engine air intake thereby reducing the potential for major damage and possible ignition of the flammable material in the surrounding atmosphere.

The E Series range of Wyndham Page automatic engine air intake shut down valves are suitable for installation in the intakes of either naturally aspirated or turbocharged engines.

Once installed and set, the repeatability of the actual engine automatic shut down speed has a greater scatter in the case of turbocharged engines than for naturally aspirated types. However, unless there is a special requirement for a very precise shut down speed, adequate protection from excessive engine overspeed is achieved.

Enhanced Protection

The Wyndham Page E series of intake shut down valves are also available with cable operated manual shut down. Contact Wyndham Page or your Wyndham Page supplier for details of this additional safety feature.

Principle of Operation

The actuation force to close the valve is derived from the engine intake air flow passing through the valve. As the air flow increases this actuation force also increases. This force is resisted by an internal valve spring, the pre-load of which is adjusted via the “Trip Adjuster Screw”.

Once the actuation force exceeds the resisting force of the valve spring, the valve rapidly moves to the closed position. Once closed the E valve remains shut until the engine has fully stopped. The valve then resets to the open position after a delay of some seconds.

Description & Main Dimensions

A typical valve of the E Series is shown below.

The overall dimensions for the range of valves are given on page 5.

The valve is supplied complete with hose adaptors [to slide into the engine air intake hose] as selected in consultation with the customer from a range typical for the rating of the engine to be protected.

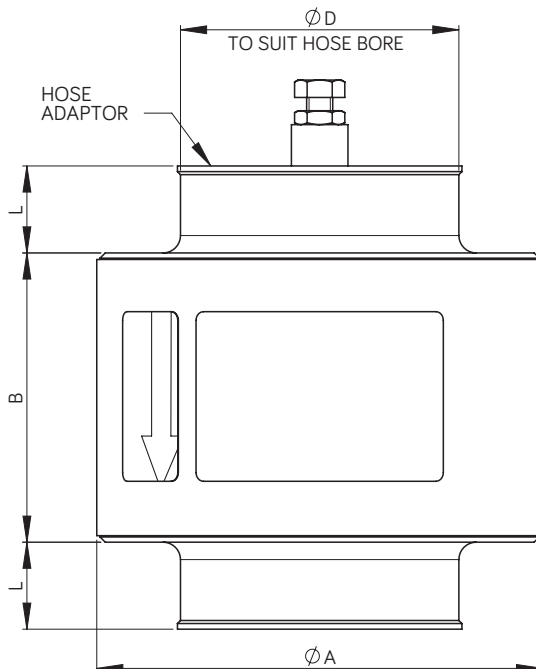

METRIC TABLE	ENGINE POWER RANGE (KW)		DIMENSIONS (MM)											
MODEL	MIN	MAX	A	B	L (MAX)	MASS (KG)	STOCK HOSE ADAPTORS D (OTHER SIZES AVAILABLE ON REQUEST)							
E02	3	18	66	52.5	20	0.26	25	35	38	45				
E05	4	27	81	52.5	20	0.35	35	38	41	45	48	51		
E10	7.5	45	102.5	66.5	20	0.57	45	48	51	58	60	62	64	70
E20	30	78	121.5	69	20	0.7	51	60	64	70	77			
E30	40	90*	130	75.5	20	0.9	70	77	83	89	100			
E40	50	110*	144	87	25	1.2	70	77	83	89	102			
E50	80	140*	158	92.5	25	1.5	89	98	102					
E60	100	185*	175	97.5	25	1.9	89	102	114					
E70	130	235*	207	112.5	25	3.1	102	121	127	140				
E80	150	290*	232	122.5	30	3.8	153							
E90	270	450*	303	210-152	30 - 40	8.5	152 TO 229 - TO ORDER							

IMPERIAL TABLE	ENGINE POWER RANGE (HP)		DIMENSIONS (INCHES)											
MODEL	MIN	MAX	A	B	L (MAX)	MASS (LB)	STOCK HOSE ADAPTORS D (OTHER SIZES AVAILABLE ON REQUEST)							
E02	4	24	2.60	2.07	0.79	0.6	1.0	1.4	1.5	1.8				
E05	5	36	3.19	2.07	0.79	0.8	1.4	1.5	1.6	1.8	1.9	2.0		
E10	10	60	4.04	2.62	0.79	1.3	1.8	1.9	2.0	2.3	2.4	2.4	2.5	2.8
E20	40	105	4.78	2.72	0.79	1.5	2.0	2.4	2.5	2.8	3.0			
E30	54	121*	5.12	2.97	0.98	2.0	2.8	3.0	3.3	3.5	3.9			
E40	67	148*	5.67	3.43	0.98	2.6	2.8	3.0	3.3	3.5	4.0			
E50	107	188*	6.22	3.64	0.98	3.3	3.5	3.9	4.0					
E60	134	248*	6.89	3.84	0.98	4.2	3.5	4.0	4.5					
E70	174	315*	8.15	4.43	0.98	6.8	4.0	4.8	5.0	5.5				
E80	201	389*	9.13	4.82	1.18	8.4	6.0							
E90	362	603*	11.93	8.3-6.0	1.2 - 1.6	18.7	6 TO 9 TO ORDER							

Power values marked * may be increased under certain restricted circumstances. Contact Wyndham Page or your Wyndham Page supplier for details. Data subject to change.

Valve Selection

To enable Wyndham Page to select the most suitable shut down valve for a given application the following data is required:

- Engine type and model.
- Engine rating and or application details.
- The internal bore of the intake system hose at the position the valve is to be fitted.

Order Coding

EXX - XXX - XXX - SXXX



Use metric value for adaptor code, add zero to make 3 digit code e.g. 25 = 025

Combine inlet and outlet adaptor codes if the same.

Special features by arrangement with Wyndham Page.

Valve Installation

Subject to the comments below, generally install the Wyndham Page E Series valve as close to the engine intake manifold as possible and in a manner that adjustment and locking of the setting screw is possible.

When fitting always ensure the direction of air flow is in compliance with the arrow marked on the body of the valve. The valve may be fitted in any attitude from vertical to horizontal.

Turbocharged Engines

In the case of turbocharged engines fit the valve upstream [air cleaner side] of the turbocharger. If an intercooler [charge cooler] is also fitted, site the valve down stream of the intercooler or, if this is not possible, fit upstream of the turbocharger. Never fit between turbocharger and intercooler.

Flametraps

In all cases where an intake flametrap is also fitted, the Wyndham Page valve must be installed upstream of the flametrap.

Hose Fitting

The hose into which the valve is fitted should be adequate to fully support the valve whilst not permitting excessive vibration of the valve. For the heavier valves in the range a support bracket for the valve may be necessary. Generally ensure that there is sufficient flexibility in the finalised intake system installation to allow for the relative movement between the system components over the full range of engine operating conditions thereby avoiding excessive mechanical stresses.

Multiple Intakes

In the case of an engine with multiple intake systems requiring the fitting of more than one Wyndham Page E valve, a suitable balance pipe must be installed between the intake system pipes downstream [engine side] of the valves to give simultaneous shut down of the fitted valves. Typically such a balance pipe should be 30% to 40% of the intake pipe diameter.

Crankcase Breathers

Any engine crankcase breather arrangement venting directly into the intake ports or into the air intake system downstream of the Wyndham Page E valve must be sealed and replaced by an external breather system connected to the intake system upstream of the E valve or [if permitted at the operating site] vented to atmosphere.

Valve Trip Speed Setting

The Wyndham Page E valve as supplied will normally be set to trip at a speed below that required.

To adjust the trip speed use the trip adjuster screw and associated lock nut. See diagram below.

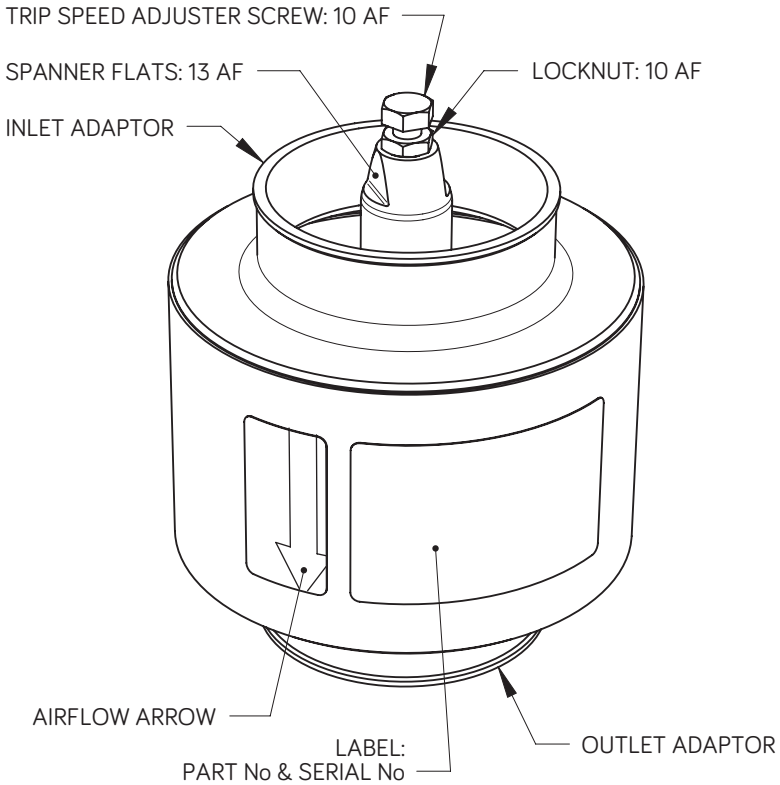

Rotating the adjuster screw clockwise increases the trip speed. To set :

- [1]. Check adjuster screw locknut is tight and that the intake system from air cleaner to intake manifold is fitted and secured and is leak free.
- [2]. Start engine. Slowly increase speed until a shut down occurs. [Note; if no shut down occurs up the maximum available engine speed with maximum throttle, remove air hose connection from the inlet end of the Wyndham Page valve as necessary to gain access to the setting screw and locknut. Release setting screw locknut and rotate the setting screw two turns anticlockwise. Tighten locknut, refit hose and recheck for shutdown].
- [3]. Following initial shut down remove air hose at the inlet end of the shut down valve as necessary to gain access to the setting screw and lock nut.
- [4]. Release setting screw locknut and rotate setting screw one turn clockwise.
- [5]. Tighten locknut, refit hose, start engine and slowly increase speed up to the maximum available.
- [6]. Repeat steps [3], [4] and [5] until the first time that no shut down occurs up to the highest speed available. Then adjust the setting screw a further one half turn clockwise and tighten the locknut. With the intake system fully fitted and the engine fully warmed up slowly run up and down the engine speed range a number of times to check no further shut down occurs.

If a further shut down occurs reset the adjuster screw one further half turn clockwise and check again until no shut down occurs.

Notes:

In the case of turbocharged engines it is important that the final check above is carried out with the engine under load.

A more precise method to set the trip speed is achieved by monitoring and recording the engine speed during adjustment and by temporarily raising the engine high idle speed [if safe to do so] to enable the final trip setting speed to be measured. Once the trip speed is set, the high idle must be reset to its standard setting.

Maintenance

The following maintenance schedule should be undertaken. Subject to experience of local operating conditions the frequency of the maintenance requirements may need to be varied.

- MONTHLY:
- [1]. Check intake pipework between valve and engine to ensure all pipe fixings and any support brackets are properly fitted and secure and that the engine intake is leak free and shows no signs of significant damage.
 - [2]. Check the shut down trip speed setting is correct by either:
 - [a]. Carrying out the trip speed adjustment as outlined herein or;
 - [b]. Temporarily raise the engine high idle and check trip speed using an engine tacho.
- 3 MONTHLY:
- [1]. Remove valve.
 - [2]. Clean valve as necessary using a soft brush/air line plus white spirit or similar if necessary taking all normal precautions. Dry valve.
 - [3]. Check that the valve moves smoothly over its complete operating stroke and that there are no signs of significant damage or excessive wear. Do not lubricate.
 - [4]. Refit valve and complete “monthly “ checks as above.
- NOTES:
- [a]. Carry out the above maintenance whilst the engine is in a non-hazardous area.
 - [b]. Where applicable ensure that the high idle speed of the engine is reset to the correct value.
 - [c]. Any problems identified must be rectified before returning the equipment to a hazardous area.

wyndham | page

Unit 1c Chalwyn Industrial Estate, Parkstone, Poole,
Dorset BH12 4PE United Kingdom

Tel: +44 (0)1202 734 656

Email: sales@wyndhampage.com

www.wyndhampage.com