

E-M Series

Combined Manual and Automatic Engine Overspeed Shut Down Valves

A range of easily installed diesel engine air intake valves which automatically close on engine overspeed and also incorporate a manual shut down feature for additional safety.



wyndham|page

Application

The E-M Series of Wyndham Page combined manual and automatic overspeed air intake shut down valves are designed for situations where flammable gas or vapour may enter the atmosphere in an area in which a diesel engine is operating.

Should such flammable material be drawn into the engine intake this may result in uncontrolled engine overspeed and a situation in which shut down of the normal diesel fuel supply may fail to stop the engine.

Under these circumstances a rapid shut down of the engine is required by immediate closure of the engine air intake thereby reducing the potential for major damage and possible ignition of the flammable material in the surrounding atmosphere.

The E-M range of Wyndham Page automatic engine air intake shut down valves are suitable for installation in the intakes of either naturally aspirated or turbocharged engines.

Once installed and set, the repeatability of the actual engine automatic shut down speed has a greater scatter in the case of turbocharged engines than for naturally aspirated types. However, unless there is a special requirement for a very precise shut down speed, adequate protection from excessive engine overspeed is achieved.

Principle of Operation [Automatic Overspeed Shutdown]

The actuation force to close the valve is derived from the engine intake air flow passing through the valve. As the air flow increases this actuation force also increases. This force is resisted by an internal valve spring, the pre-load of which is adjusted via the "Trip Adjuster Screw".

Once the actuation force exceeds the resisting force of the valve spring, the valve rapidly moves to the closed position. Once closed the E-M valve remains shut until the engine has fully stopped. The valve then resets to the open position after a delay of some seconds.

Enhanced Protection [Manual Shutdown]

The Wyndham Page E-M series of automatic overspeed intake shut down valve kits include a manual actuator connected to the valve via a mechanical cable to enable manual emergency valve closure.

Description & Main Dimensions

A typical E-M Series valve is shown below. The overall dimensions for this range of valves are given on page 4.

The valve is supplied complete with hose adaptors selected in consultation with the customer from a range typical for the rating of the engine to be protected and as tabulated on page 4. The standard stocked lengths from which the manual shut down cable may be selected are also given on page 4. Alternative cable lengths may be available on application.

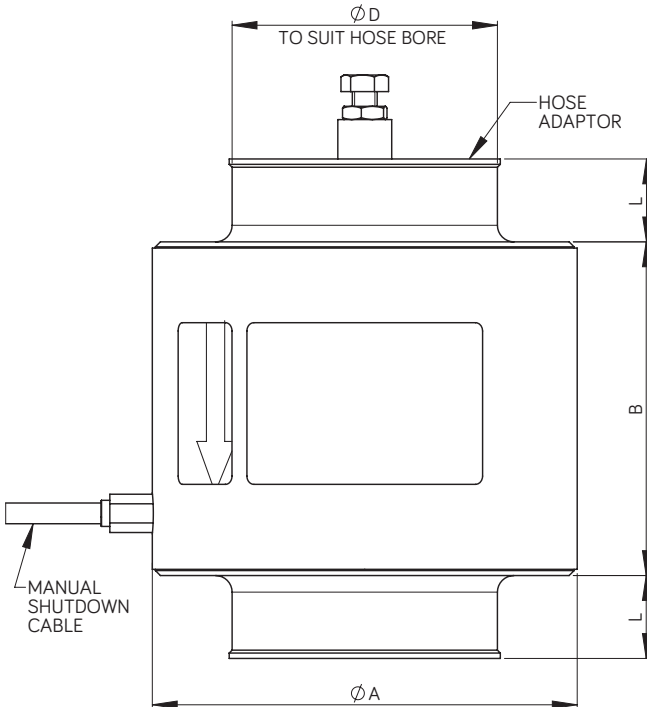

DIAGRAM OF TYPICAL VALVE SHOWING DIMENSION DATUMS
EQUATING TO TABLE ON PAGE 4.

METRIC TABLE	ENGINE POWER RANGE (KW)		DIMENSIONS (MM)											
MODEL	MIN	MAX	A	B	L (MAX)	MASS (KG)	STOCK HOSE ADAPTORS D (OTHER SIZES AVAILABLE ON REQUEST)							
E02M	3	18	66	65	20	0.26	25	35	38	45				
E05M	4	27	81	65	20	0.35	35	38	41	45	48	51		
E10M	7.5	45	102.5	80.5	20	0.57	45	48	51	58	60	62	64	70
E20M	30	78	121.5	83.5	20	0.7	51	60	64	70	77			
E30M	40	90*	130	90	20	0.9	70	77	83	89				
E40M	50	110*	144	101	25	1.2	70	77	83	89				
E50M	80	140*	158	109.5	25	1.5	89	98	102					
E60M	100	185*	175	114.5	25	1.9	89	102	114					
E70M	130	235*	207	131	25	3.1	102	121	127	140				
E80M	150	290*	232	141.5	30	3.8	153							
E90M	270	450*	303	210 - 158	30 - 40	8.5	152 TO 229 - TO ORDER							

IMPERIAL TABLE	ENGINE POWER RANGE (HP)		DIMENSIONS (INCHES)											
MODEL	MIN	MAX	A	B	L (MAX)	MASS (LB)	STOCK HOSE ADAPTORS D (OTHER SIZES AVAILABLE ON REQUEST)							
E02M	4	24	2.60	2.36	0.79	0.6	1.0	1.4	1.5	1.8				
E05M	5	36	3.19	2.36	0.79	0.8	1.4	1.5	1.6	1.8	1.9	2.0		
E10M	10	60	4.04	2.99	0.79	1.3	1.8	1.9	2.0	2.3	2.4	2.4	2.5	2.8
E20M	40	105	4.78	3.17	0.79	1.5	2.0	2.4	2.5	2.8	3.0			
E30M	54	121*	5.12	3.46	0.98	2.0	2.8	3.0	3.3	3.5				
E40M	67	148*	5.67	3.78	0.98	2.6	2.8	3.0	3.3	3.5				
E50M	107	188*	6.22	4.06	0.98	3.3	3.5	3.9	4.0					
E60M	134	248*	6.89	4.29	0.98	4.2	3.5	4.0	4.5					
E70M	174	315*	8.15	4.92	0.98	6.8	4.0	4.8	5.0	5.5				
E80M	201	389*	9.13	5.31	1.18	8.4	6.0							
E90M	362	603*	11.93	8.3 - 6.2	1.2 - 1.6	18.7	6 TO 9 TO ORDER							

Power values marked* may be increased under certain restricted circumstances.
Contact Wyndham Page or your Wyndham Page supplier for details. Data subject to change.

Valve Selection

To enable Wyndham Page to select the most suitable shut down valve for a given application the following data is required:

- Engine type and model.
- Engine rating and / or application details.
- The internal bore of the intake system hose at the position the valve is to be fitted.
- The cable length for the manual shut down.

Order Coding

EXXM - XXX - XXX - RXX - SXXX

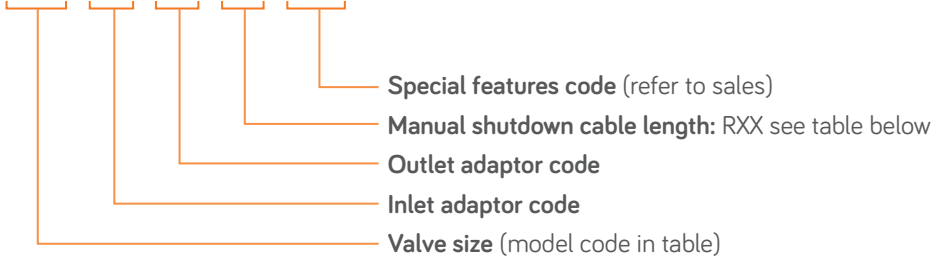

Use metric value for adaptor code, add zero to make 3 digit code e.g. 25 = 025

Combine inlet and outlet adaptor codes if the same.

Special features by arrangement with Wyndham Page.

STANDARD CABLE LENGTHS	
CABLE CODE	LENGTH (M)
05	0.5
10	1.0
15	1.5
20	2.0
25	2.5
30	3.0

Valve Installation

Wyndham Page E-M valves are supplied complete with the manual shut down pull handle and the selected length of shut down cable fitted and adjusted. It is recommended that the pull handle and cable are not separated from the valve when installing.

Subject to the comments below generally install the Wyndham Page E-M Series valve as close to the engine intake manifold as practical. Always ensure following installation that:

[a]. Adjustment and locking of the setting screw is possible.

[b]. A suitable run for the manual shut down cable is accommodated.

In the case of turbocharged engines fit the valve upstream [air cleaner side] of the turbocharger. If an intercooler [charge cooler] is also fitted, site the valve down stream of the intercooler or, if this is not possible, fit upstream of the turbocharger. Never fit between turbocharger and intercooler.

In all cases where an intake flametrap is also fitted, the Wyndham Page valve must be installed upstream of the flametrap.

When fitting always ensure the direction of air flow is in compliance with the arrow marked on the body of the valve. The valve may be fitted in any attitude from vertical to horizontal.

The hose into which the valve is fitted should be adequate to fully support the valve whilst not permitting excessive vibration of the valve. For the heavier valves in the range a support bracket for the valve may be necessary.

Generally ensure that there is sufficient flexibility in the finalised intake system installation to allow for the relative movement between the system components over the full range of engine operating conditions thereby avoiding excessive mechanical stresses.

In the case of an engine with multiple intake systems requiring the fitting of more than one Wyndham Page E-M valve, a suitable balance pipe must be installed between the intake system pipes downstream [engine side] of the valves to give simultaneous shut down of the fitted valves. Typically such a balance pipe should be 30% to 40% of the intake pipe diameter.

Any engine crankcase breather arrangement venting directly into the intake ports or into the air intake system downstream of the Wyndham Page E-M valve must be sealed and replaced by an external breather system connected to the intake system upstream of the E-M valve or [if permitted at the operating site] vented to atmosphere.

For valve types E02M to E40M a pull “T” handle is supplied for manual emergency valve closure. Valve types E50M to E80M have a lever operated manual shut down actuator. Both types are shown over on page 8. Always install the manual shut down actuator in a convenient position such that it can be easily accessed during an emergency situation. The “T” handle type can be located in a suitable bulkhead or mounting bracket by providing a 18mm diameter hole. To fit the pull handle assembly release the handle locknut and remove the handle. Remove the body locknut and washer at the handle end and push the handle body through the 18mm hole. Refit body washer and locknut adjusting both body locknuts as required. Refit handle locknut and handle and tighten. In the case of the lever type actuator supplied with the larger valve types, two 7mm diameter holes are provided through the body for fixing.

Note. Towards the upper end of the relevant E-M size range for both types of manual actuator a significant force may be required to operate when the engine is not running. Once the engine is running the force required to carry out a manual emergency stop reduces as the engine speed increases.

Important Note. Always retain the standard fuel stop provided with the engine. The E-M valve manual stop should never be used as the normal way to stop an engine. It is intended for emergency operation only or when checking for correct functioning.

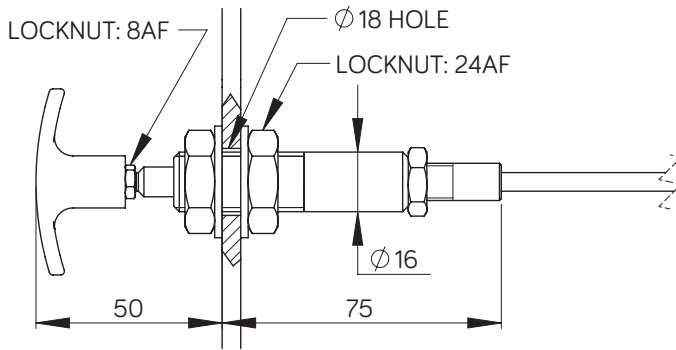

T HANDLE: FOR VALVES E02 TO E40

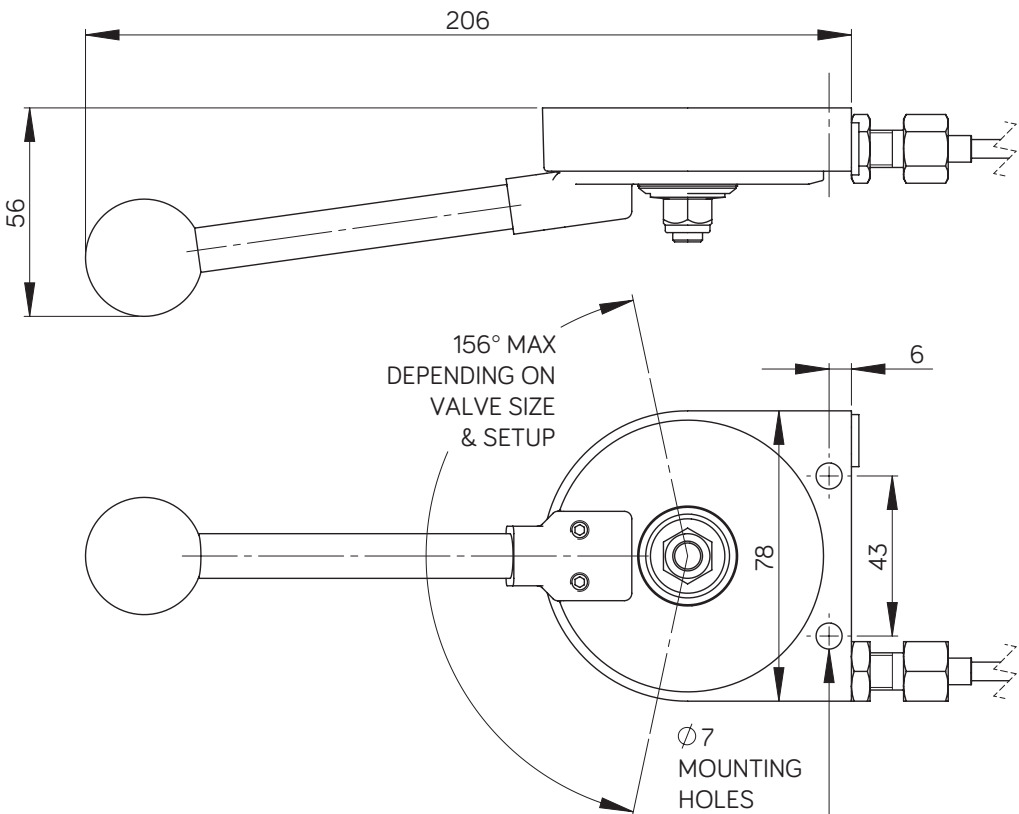

LEVER: FOR VALVES E50 TO E90

Valve Trip Speed Setting

The Wyndham Page E-M valve as supplied will normally be set to trip at a speed below that required. To adjust the trip speed use the trip adjuster screw and associated lock nut. See diagram below.

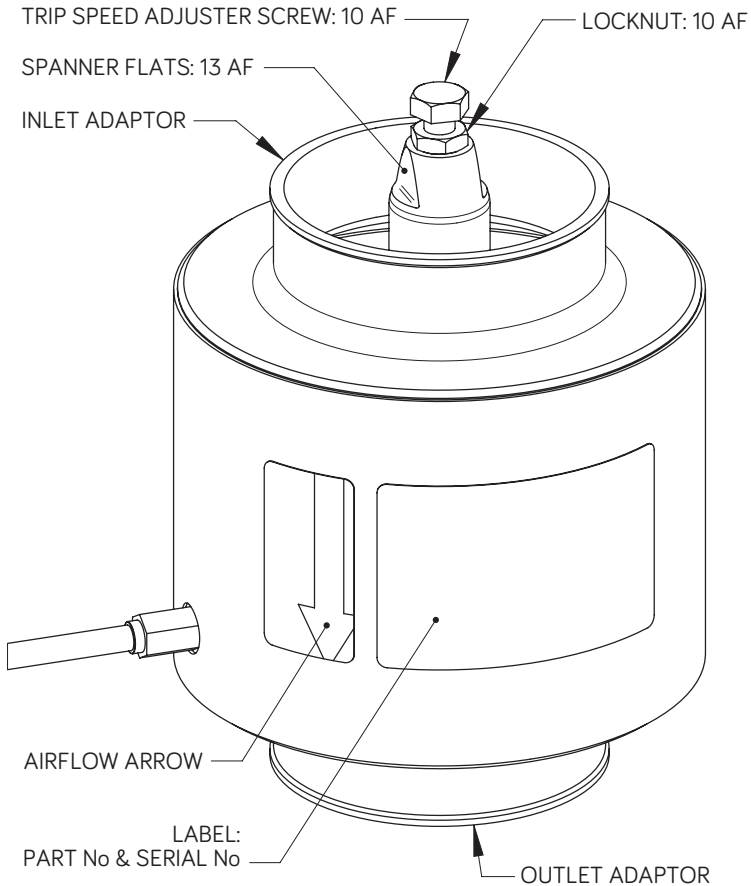

Rotating the adjuster screw clockwise increases the trip speed. Prior to attempting to set the trip speed check that the manual emergency stop pull handle is in the run condition. To set:

- [1]. Check adjuster screw locknut is tight and that the intake system from air cleaner to intake manifold is fitted and secured and is leak free.
- [2]. Start engine. Slowly increase speed until a shut down occurs. [Note; if no shut down occurs up to the maximum available engine speed with maximum throttle, remove air hose connection from the inlet end of the Wyndham Page valve as necessary to gain access to the setting screw and locknut. Release setting screw locknut and rotate the setting screw two turns anticlockwise. Tighten locknut, refit hose and recheck for shutdown].
- [3]. Following initial shut down remove air hose at the inlet end of the shut down valve as necessary to gain access to the setting screw and lock nut.
- [4]. Release setting screw locknut and rotate setting screw one turn clockwise.
- [5]. Tighten locknut, refit hose as necessary, start engine and slowly increase speed up to the maximum available.
- [6]. Repeat steps [3], [4] and [5] until the first time that no shut down occurs up to the highest speed available. Then adjust the setting screw a further one half turn clockwise and tighten the locknut. With the intake system fully fitted and the engine fully warmed up, slowly run up and down the engine speed range a number of times to check no further shut down occurs. If a further shut down occurs reset the adjuster screw one further half turn clockwise and check again until no shut down occurs.
- [7]. Finally restart engine and run at about half maximum speed [or higher if this not possible]. Operate the manual emergency stop to ensure that the engine stops within a few seconds.

Notes:

In the case of turbocharged engines it is important that the final check above is carried out with the engine under load.

A more precise method to set the trip speed is achieved by monitoring and recording the engine speed during adjustment and by temporarily raising the engine high idle speed [if safe to do so] to enable the final trip setting speed to be measured. Once the trip speed is set, the high idle must be reset to its standard setting.

Maintenance

The following maintenance schedule should be undertaken. Subject to experience of local operating conditions the frequency of the maintenance requirements may need to be varied.

- DAILY: Run engine at mid range speed [or higher if this not possible].
Operate the manual emergency stop. The engine should stop within a few seconds.
- MONTHLY: [1]. Check intake pipework between valve and engine to ensure all pipe fixings and any support brackets are properly fitted and secure and that the engine intake is leak free and shows no signs of significant damage.
- [2]. Check the shut down trip speed setting is correct by either :
- [a] Carrying out the trip speed adjustment as outlined herein or;
[b] Temporarily raise the engine high idle and check trip speed using an engine tachometer.
- 3 MONTHLY: [1]. Remove valve complete with manual stop handle and cable.
- [2]. Clean valve as necessary using a soft brush / air line plus white spirit or similar if necessary taking all normal precautions. Dry valve.
- [3]. Check that the valve moves smoothly over its complete operating stroke and that there are no signs of significant damage or excessive wear. Do not lubricate.
- [4]. Check the manual stop handle and cable for damage or wear. Check for freedom of operation.
- [5]. Refit valve and complete “daily and monthly” checks as above.
- NOTES: [a]. Carry out the above maintenance whilst the engine is in a non-hazardous area.
- [b]. Where applicable ensure that the high idle speed of the engine is reset to the correct value.
- [c]. Any problems identified must be rectified before returning the equipment to a hazardous area.

wyndham | page

Unit 1c Chalwyn Industrial Estate, Parkstone, Poole,
Dorset BH12 4PE United Kingdom

Tel: +44 (0)1202 734 656

Email: sales@wyndhampage.com

www.wyndhampage.com